

# PABRIK BARIUM KARBONAT DARI BARIUM SULFIDE DAN KARBON DIOKSIDA (CO<sub>2</sub>)

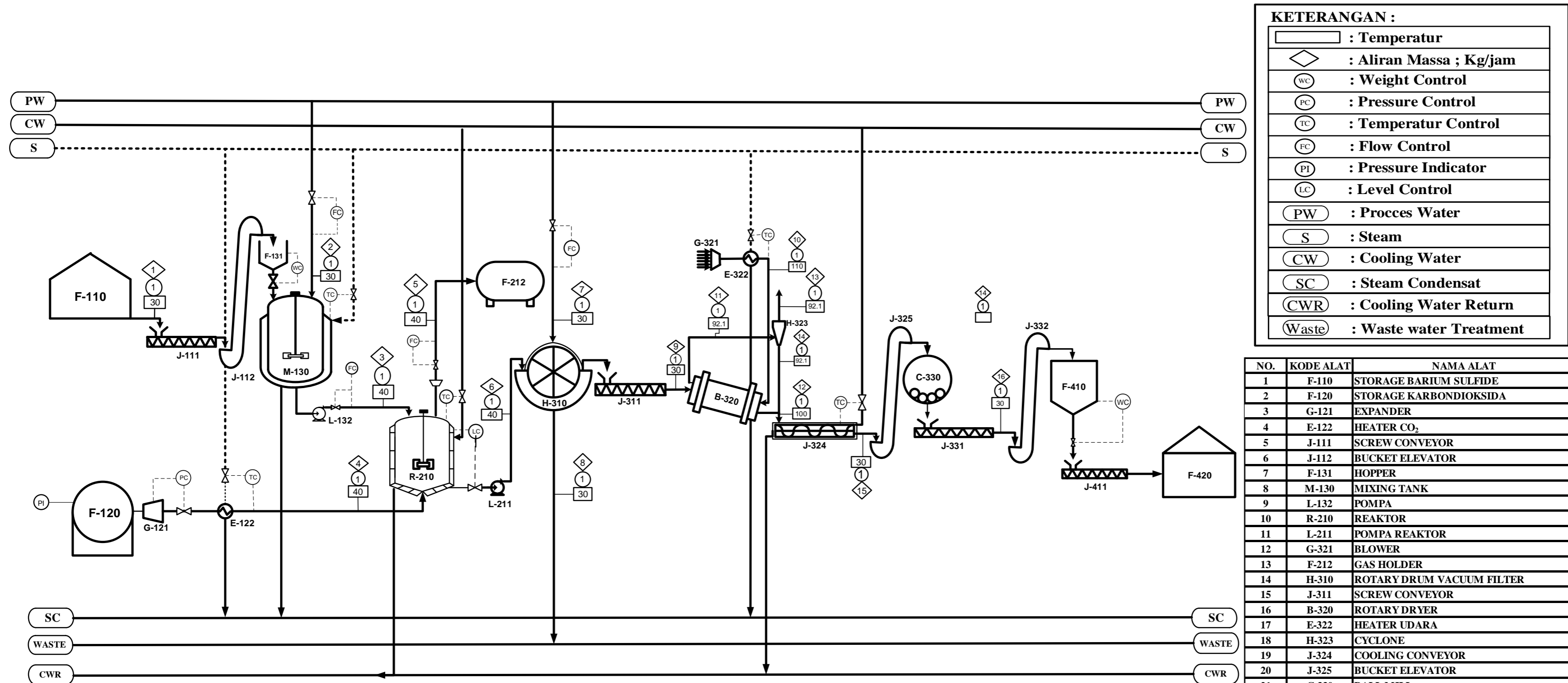

**KETERANGAN :**

	: Temperatur
	: Aliran Massa ; Kg/jam
	: Weight Control
	: Pressure Control
	: Temperatur Control
	: Flow Control
	: Pressure Indicator
	: Level Control
	: Proses Water
	: Steam
	: Cooling Water
	: Steam Condensat
	: Cooling Water Return
	: Waste water Treatment

NO.	KODE ALAT	NAMA ALAT
1	F-110	STORAGE BARIUM SULFIDE
2	F-120	STORAGE KARBONDIOKSIDA
3	G-121	EXPANDER
4	E-122	HEATER CO <sub>2</sub>
5	J-111	SCREW CONVEYOR
6	J-112	BUCKET ELEVATOR
7	F-131	HOPPER
8	M-130	MIXING TANK
9	L-132	POMPA
10	R-210	REAKTOR
11	L-211	POMPA REAKTOR
12	G-321	BLOWER
13	F-212	GAS HOLDER
14	H-310	ROTARY DRUM VACUUM FILTER
15	J-311	SCREW CONVEYOR
16	B-320	ROTARY DRYER
17	E-322	HEATER UDARA
18	H-323	CYCLONE
19	J-324	COOLING CONVEYOR
20	J-325	BUCKET ELEVATOR
21	C-330	BALL MILL
22	J-331	SCREW CONVEYOR
23	J-332	BUCKET ELEVATOR
24	F-410	SILO BARIUM KARBONAT
25	J-411	SCREW CONVEYOR
26	F-420	STORAGE BARIUM KARBONAT

Komponen	Aliran Massa (Kg/Jam)															
	1	2	3	4	5	6	7	8	9	10	11	12	13	14	15	16
BaS	6636,31	-	6636,31	-	-	132,726	-	131,693	1,03335	-	0,01033	1,02301	0,01023	1,03324	0,05166	1,08491
CO <sub>2</sub>	-	-	-	1723,51	34,4703	-	-	-	-	-	-	-	-	-	-	-
H <sub>2</sub> O	-	44568,9	44568,9	17,4092	-	43895,4	10334,3	53888	341,749	-	296,473	45,2762	-	45,2762	2,26381	47,54
BaCO <sub>3</sub>	-	-	-	-	-	7576,52	-	-	7576,52	-	75,7652	7500,75	75,0075	7575,76	384,455	7954,55
H <sub>2</sub> S	-	-	-	-	1305,17	-	-	-	-	-	-	-	-	-	-	-
C	67,0335	-	67,0335	-	-	67,0335	-	-	67,0335	-	0,67033	66,3631	0,66363	67,0268	3,35134	70,3781
Udara	-	-	-	-	-	-	-	-	-	15578,5	15578,5	-	-	-	-	-
<b>Total</b>	<b>6703,35</b>	<b>44568,9</b>	<b>51272,3</b>	<b>1740,92</b>	<b>1339,64</b>	<b>51671,6</b>	<b>10334,3</b>	<b>54019,6</b>	<b>7986,33</b>	<b>15578,5</b>	<b>15951,4</b>	<b>7613,41</b>	<b>75,6814</b>	<b>7689,09</b>	<b>390,121</b>	<b>8073,55</b>

FLWSHEET PRA RANCANGAN PABRIK BARIUM KARBONAT DARI BARIUM SULFIDA DAN KARBONDIOKSIDA

OLEH : LEONA ROUDHOTUL JANNAH  
 NPM : 18031010007  
 DOSEN PEMBIMBING

Ir. MU'TASIM BILLAH, MS  
 PROGRAM STUDI TEKNIK KIMIA  
 FAKULTAS TEKNIK  
 UNIVERSITAS PEMBANGUNAN NASIONAL "VETERAN"  
 JAWA TIMUR  
 2022

# UNIT PENGOLAHAN AIR PABRIK BARIUM KARBONAT DARI BARIUM SULFIDE DENGAN KARBON DIOKSIDA

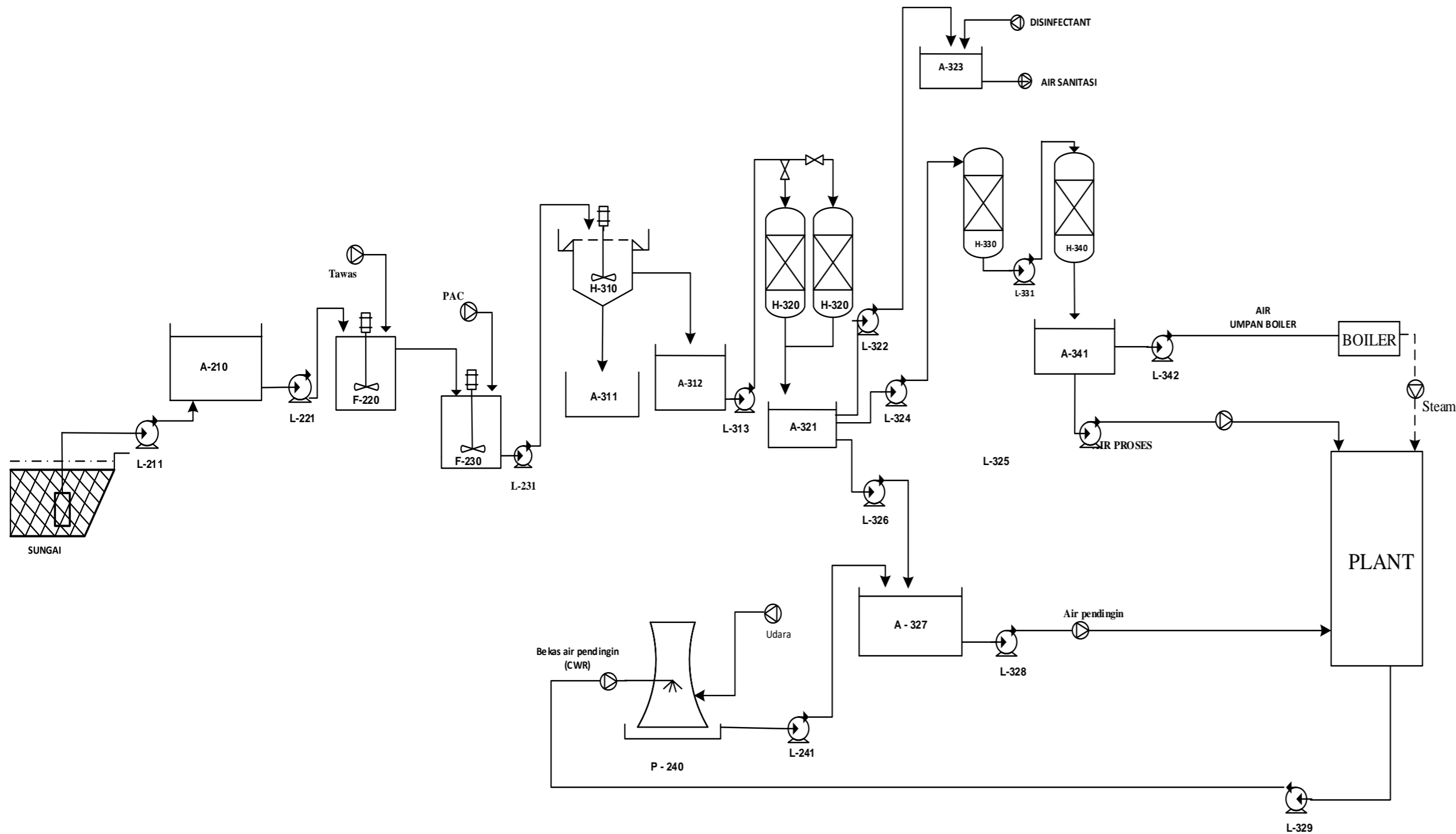

NO	KODE	NAMA ALAT
1	L-211	POMPA - 1
2	A-210	BAK PENAMPUNG AIR SUNGAI
3	L-221	POMPA - 2
4	F - 220	TANGKI KOAGULASI
5	F - 230	TANGKIFLOKULASI
6	L - 231	POMPA - 3
7	P - 240	COOLING TOWER
8	L - 241	POMPA - 4
9	H - 310	CLARIFIER
10	A - 311	BAK PENAMPUNG FLOK
11	A - 312	BAK PENAMPUNG AIR BERSIH
12	L - 313	POMPA - 5
13	H - 320	SAND FILTER
14	A - 321	BAK PENAMPUNG AIR BERSIH
15	L - 322	POMPA - 6
16	A - 323	BAK AIR SANITASI
17	L - 324	POMPA - 7
18	H - 330	TANGKIKATION EXCHANGER
19	L - 331	POMPA - 8
20	H - 340	TANGKIANION EXCHANGER
21	A - 341	TANGKI AIR DEMINERALISASI
22	L - 342	POMPA - 9
23	L - 343	POMPA - 10
24	L - 325	POMPA - 11
25	A - 326	BAK PENAMPUNG AIR PENDINGIN
26	L - 327	POMPA - 12
27	L - 328	POMPA - 13

**FLWSHEET UNIT PENGOLAHAN AIR PABRIK BARIUM KARBONAT DARI BARIUM SULFIDA DAN KARBONDIOKSIDA**

**OLEH :** LEONA ROUDHOTUL JANNAH  
**NPM :** 18031010007

**DOSEN PEMBIMBING**

Tr. Mu'tasim Billah, MS

PROGRAM STUDI TEKNIK KIMIA  
 FAKULTAS TEKNIK  
 UNIVERSITAS PEMBANGUNAN NASIONAL "VETERAN"  
 JAWA TIMUR  
 2022

