

FLOWSHEET PRA RANCANGAN PABRIK AMMONIUM NITRATE DARI AMMONIA DAN ASAM NITRAT DENGAN PROSES VACUUM CRYSTALLIZATION KAPASITAS 75.000 TON/TAHUN

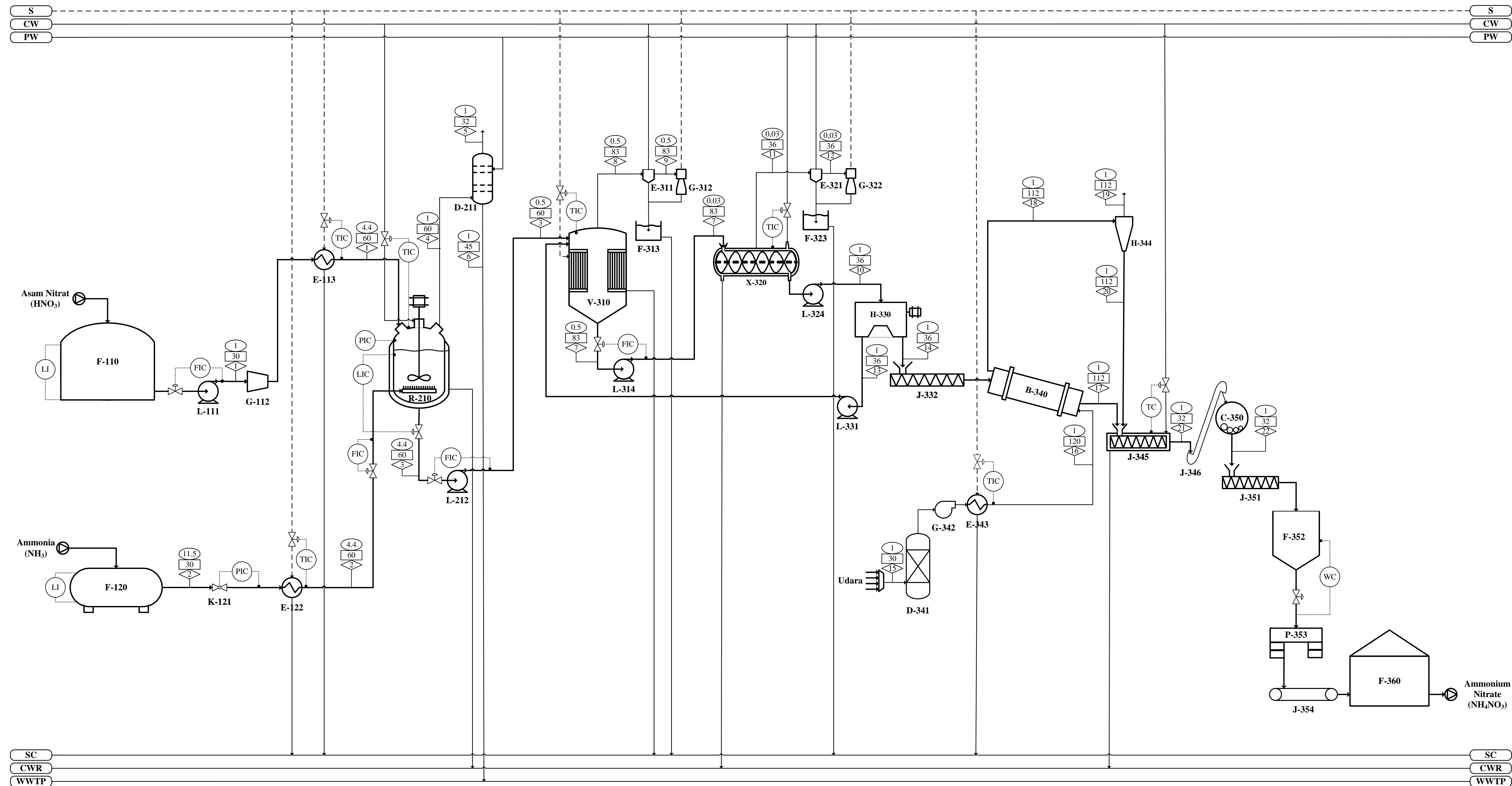

Keterangan:	
	Tekanan (atm)
	Temperatur (°C)
	Aliran Massa (kg/jam)
	Steam
	Cooling Water
	Process Water
	Steam Condensate
	Cooling Water Return
	Waste Water Treatment Plant

No.	Kode Alat	Nama Alat
1	F-110	Tangki Penyimpanan Asam Nitrat
2	L-111	Pompa 1
3	G-112	Compressor
4	E-113	Heater 1
5	F-120	Tangki Penyimpanan Ammonia
6	K-121	Expansion Valve
7	E-122	Heater 2
8	R-210	Reaktor
9	D-211	Absorber
10	L-212	Pompa 2
11	V-310	Evaporator
12	E-311	Barometric Condensor 1
13	G-312	Steam Jet Ejector 1
14	F-313	Hotwell 1
15	L-314	Pompa 3
16	X-320	Crystallizer
17	E-321	Barometric Condensor 2
18	G-322	Steam Jet Ejector 2
19	F-323	Hotwell 2
20	L-324	Pompa 4
21	H-330	Centrifuge
22	L-331	Pompa 5
23	J-332	Screw Conveyor 1
24	B-340	Rotary Dryer
25	D-341	Molecular Sieve Air Dryer
26	G-342	Blower
27	E-343	Heater 3
28	H-344	Cyclone
29	J-345	Cooling Screw Conveyor
30	J-346	Bucket Elevator
31	C-350	Ball Mill
32	J-351	Screw Conveyor 2
33	F-352	Bin Ammonium Nitrate
34	P-353	Unit Pengemasan Ammonium Nitrate
35	J-354	Roller Conveyor
36	F-360	Gudang Penyimpanan Ammonium Nitrate

PROGRAM STUDI TEKNIK KIMIA
FAKULTAS TEKNIK DAN SAINS
UNIVERSITAS PEMBANGUNAN NASIONAL "VETERAN"
JAWA TIMUR
2024

FLOWSHEET PRA RANCANGAN PABRIK AMMONIUM NITRATE
DARI AMMONIA DAN ASAM NITRAT DENGAN PROSES VACUUM
CRYSTALLIZATION KAPASITAS 75.000 TON/TAHUN

Dosen Pembimbing : Ir. Ketut Sumada, M.S.
Digambar Oleh : Tantri Nailis Sa'adah
(NPM. 200310101202)

Mengetahui,

Komponen	Aliran Massa (kg/jam)																					
	1	2	3	4	5	6	7	8	9	10	11	12	13	14	15	16	17	18	19	20	21	22
NH _{3(g)}		1.644,9517		16,4495	0,0822																	
HNO _{3(g)}								60,8719														
H ₂ O _(g)		1,3170		103,4459				1.091,1947	218,2389		948,7187	189,7437						7,4510	0,0745			
HNO _{3(l)}	6.087,1907		60,8719																			
H ₂ O _(l)	4.407,9657		4.305,8368			144,0644	3.794,8746			943,1864		926,2696	16,9168				9,4659			0,0745	9,5404	9,5404
NH ₄ NO _{3(aq)}			7.654,8210				7.805,0808			156,1016		153,3018	2,7998				2,7718	0,0280	0,0003	0,0003	2,7721	2,7721
NH ₄ OH _(l)						33,6860																
NH ₄ NO _{3(s)}										9.551,9488				9.551,9488			9.456,4293	95,5195	0,9552	0,9552	9.457,3845	9.457,3845
Udara															11.013,251	10.958,458						
Total	10.495,156	1.646,2687	12.021,530	119,8954	0,0822	177,7504	11.599,955	1.152,0666	218,2389	10.651,237	948,7187	189,7437	1.079,5714	9.571,6654	11.013,251	10.958,458	9.468,6670	102,9984	1,0300	1,0300	9.469,6970	9.469,6970

FLWSHEET UTILITAS PRA RANCANGAN PABRIK AMMONIUM NITRATE DARI AMMONIA DAN ASAM NITRAT DENGAN PROSES VACUUM CRYSTALLIZATION KAPASITAS 75.000 TON/TAHUN

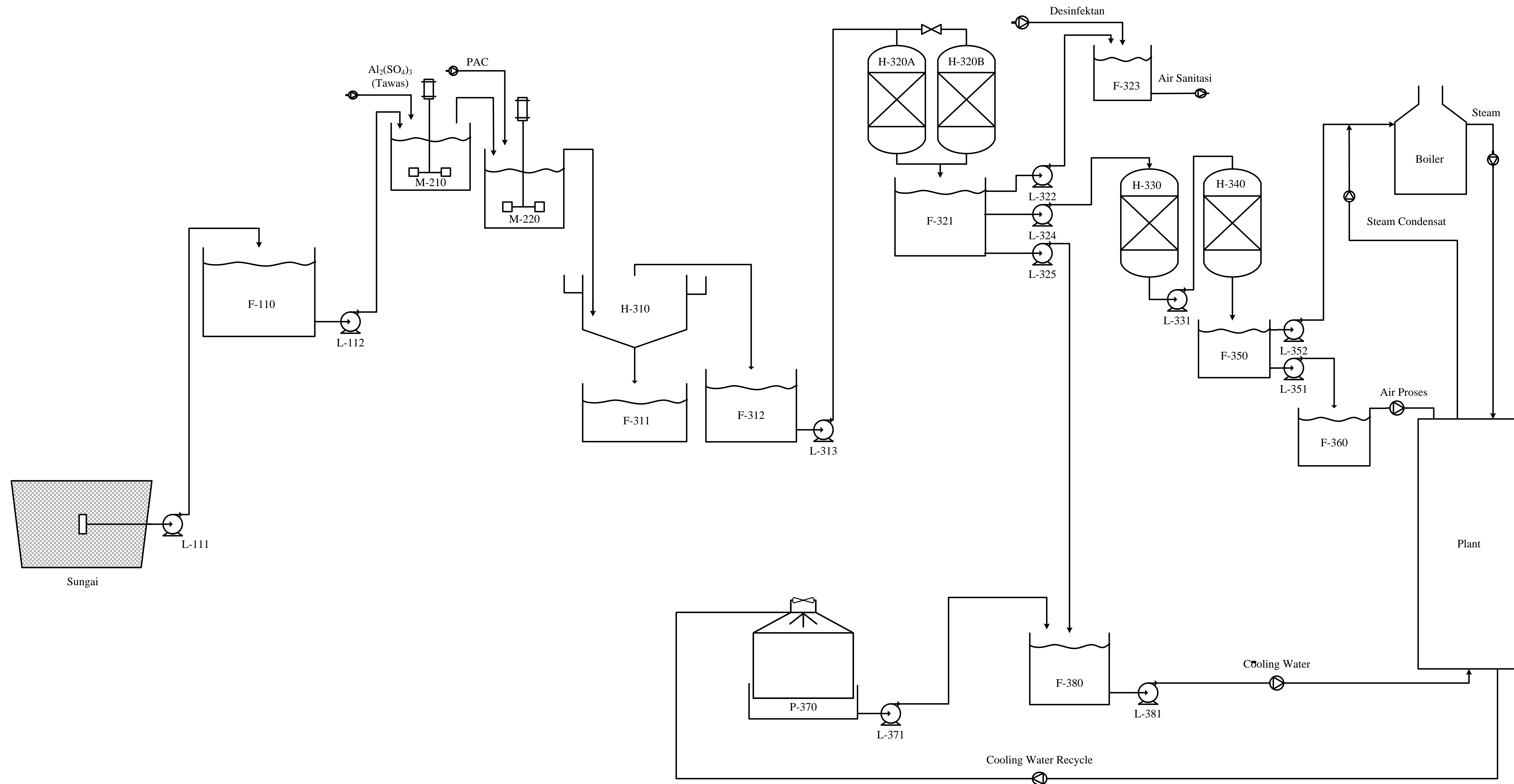

No.	Kode Alat	Nama Alat
1	F-110	Bak Penampung Air Sungai
2	L-111	Pompa 1
3	L-112	Pompa 2
4	M-210	Tangki Koagulasi
5	M-220	Tangki Flokulasi
6	H-310	Clarifier
7	F-311	Bak Penampung Flok Clarifier
8	F-312	Bak Penampung Air dari Clarifier
9	L-313	Pompa 3
10	H-320A/B	Sand Filter
11	F-321	Bak Penampung Air dari Sand Filter
12	L-322	Pompa 4
13	F-323	Bak Penampung Air Sanitasi
14	L-324	Pompa 5
15	L-325	Pompa 6
16	H-330	Kation Exchanger
17	L-331	Pompa 7
18	H-340	Anion Exchanger
19	F-350	Bak Penampung Air Demineralisasi
20	L-351	Pompa 8
21	L-352	Pompa 9
22	F-360	Bak Penampung Air Proses
23	P-370	Cooling Tower
24	L-371	Pompa 10
25	F-380	Bak Penampung Air Pendingin
26	L-381	Pompa 11

	PROGRAM STUDI TEKNIK KIMIA FAKULTAS TEKNIK DAN SAINS UNIVERSITAS PEMBANGUNAN NASIONAL "VETERAN" JAWA TIMUR 2024
FLWSHEET UTILITAS PRA RANCANGAN PABRIK AMMONIUM NITRATE DARI AMMONIA DAN ASAM NITRAT DENGAN PROSES VACUUM CRYSTALLIZATION KAPASITAS 75.000 TON/TAHUN	
Dosen Pembimbing : Ir. Ketut Sumada, M.S. Digambar Oleh : Tantri Nailis Sa'adah (NPM. 20031010202)	Mengetahui,