

PRA RENCANA PABRIK DINATRIUM FOSFAT DARI NATRIUM KARBONAT DAN ASAM FOSFAT DENGAN PROSES KRISTALISASI

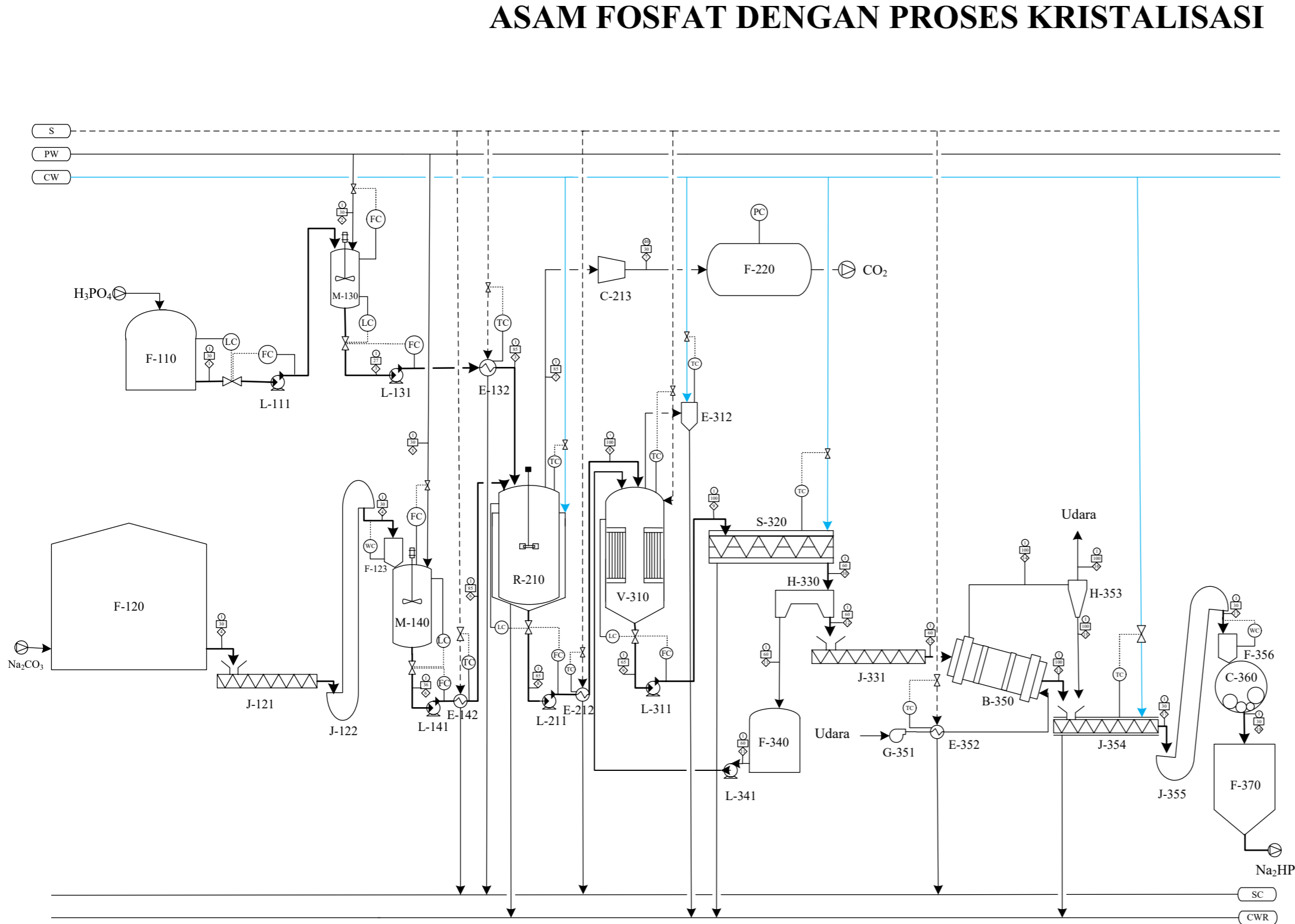

	Temperatur; °C
	Aliran Massa; kg/jam
	Tekanan; atm
	Steam: 148°C ; 4,5 atm
	Steam Condensate
	Cooling Water
	Cooling Water Retrun
	Process Water

34	F - 356	HOPPER DINATRIUM FOSFAT
33	F - 370	SILO PRODUK
32	C - 360	BALL MILL
31	J - 355	BUCKET ELEVATOR DINATRIUM FOSFAT
30	J - 354	COOLING SCREW CONVEYOR
29	H - 353	CYCLONE
28	E - 352	HEATER UDARA
27	G - 351	BLOWER UDARA
26	B - 350	ROTARY DRYER
25	L - 341	POMPA MOTHER LIQUOR
24	F - 340	TANGKI PENAMPUNG MOTHER LIQUOR
23	J - 331	SCREW CONVEYOR
22	H - 330	CENTRIFUGE
21	S - 320	CRYSTALLIZER
20	E - 312	KONDENSOR
19	L - 311	POMPA DINATRIUM FOSFAT
18	V - 310	EVAPORATOR
17	F - 220	TANGKI PENAMPUNG CO ₂ LIQUID
16	C - 213	KOMPRESOR
15	E - 212	HEATER DINATRIUM FOSFAT
14	L - 211	POMPA LARUTAN DINATRIUM FOSFAT
13	R - 210	REAKTOR
12	E - 142	HEATER NATRIUM KARBONAT
11	L - 141	POMPA NATRIUM KARBONAT
10	M - 140	TANGKI PELARUTAN NATRIUM KARBONAT
9	F - 123	HOPPER
8	J - 122	BUCKET ELEVATOR NATRIUM KARBONAT
7	J - 121	SCREW CONVEYOR NATRIUM KARBONAT
6	F - 120	PENYIMPANAN NATRIUM KARBONAT
5	E - 132	HEATER ASAM FOSFAT 75%
4	L - 131	POMPA ASAM FOSFAT 75%
3	M - 130	TANGKI PENGECERAN ASAM FOSFAT
2	L - 111	POMPA ASAM FOSFAT 85%
1	F - 110	TANGKI PENYIMPANAN ASAM FOSFAT
NO	KODE	NAMA ALAT

PRA RENCANA PABRIK DINATRIUM FOSFAT DARI NATRIUM KARBONAT DAN ASAM FOSFAT DENGAN PROSES KRISTALISASI		
Disusun Oleh	Wahyu Qur'ani Nufus	Mengetahui,
NPM	20031010151	
Dosen Pembimbing I	Ir. Mu'tasim Billah, MT	
Dosen Pembimbing II	Lilik Suprianti, S.T., M.Sc	
	PROGRAM STUDI TEKNIK KIMIA FAKULTAS TEKNIK DAN SAINS UNIVERSITAS PEMBANGUNAN NASIONAL "VETERAN" JAWA TIMUR 2024	

Komponen	1	2	3	4	5	6	7	8	9	10	11	12	13	14	15	16	17	18
Na ₂ CO ₃				9334,44		9334,44		820,89	1640,77	1640,77	1638,77	2,00	1,98	0,0028	0,02		2,00	2,00
NaCl				65,87		65,87		65,87	131,66	131,66	131,50	0,16	0,16	0,0016	0,002		0,16	0,16
H ₃ PO ₄	8285		8285					414,26	828,02	828,02	827,01	1,01	1,00	0,0099	0,01		1,01	1,01
Na ₂ HPO ₄ (aq)								11404,96	11632,78	232,66	232,37	0,28	0,28	0,0028	0,00	0,0028	0,28	0,28
Na ₂ HPO ₄ .12H ₂ O										11586,52		11586,52						
Na ₂ HPO ₄ (s)													11472,95	113,57	112,43	1,14	11585,38	11585,38
H ₂ O	1462	1299,65	2761,76	9,41	18657,15	18666,56		22874,02	5154,73	4968,34	4962,28	6,06	2,32	3,74	0,02	3,72	2,34	2,34
CO ₂							3533,93											
Total	9747	1299,65	11047,05	9409,72	18657,15	28066,87	3533,93	35579,99	19387,96	19387,96	7791,93	11596,02	11478,68	117,33	112,49	4,85	11591,17	11591,17

UNIT PENGOLAHAN AIR

PABRIK DISODIUM FOSFAT DARI NATRIUM KARBONAT DAN ASAM FOSFAT DENGAN PROSES KRISTALISASI

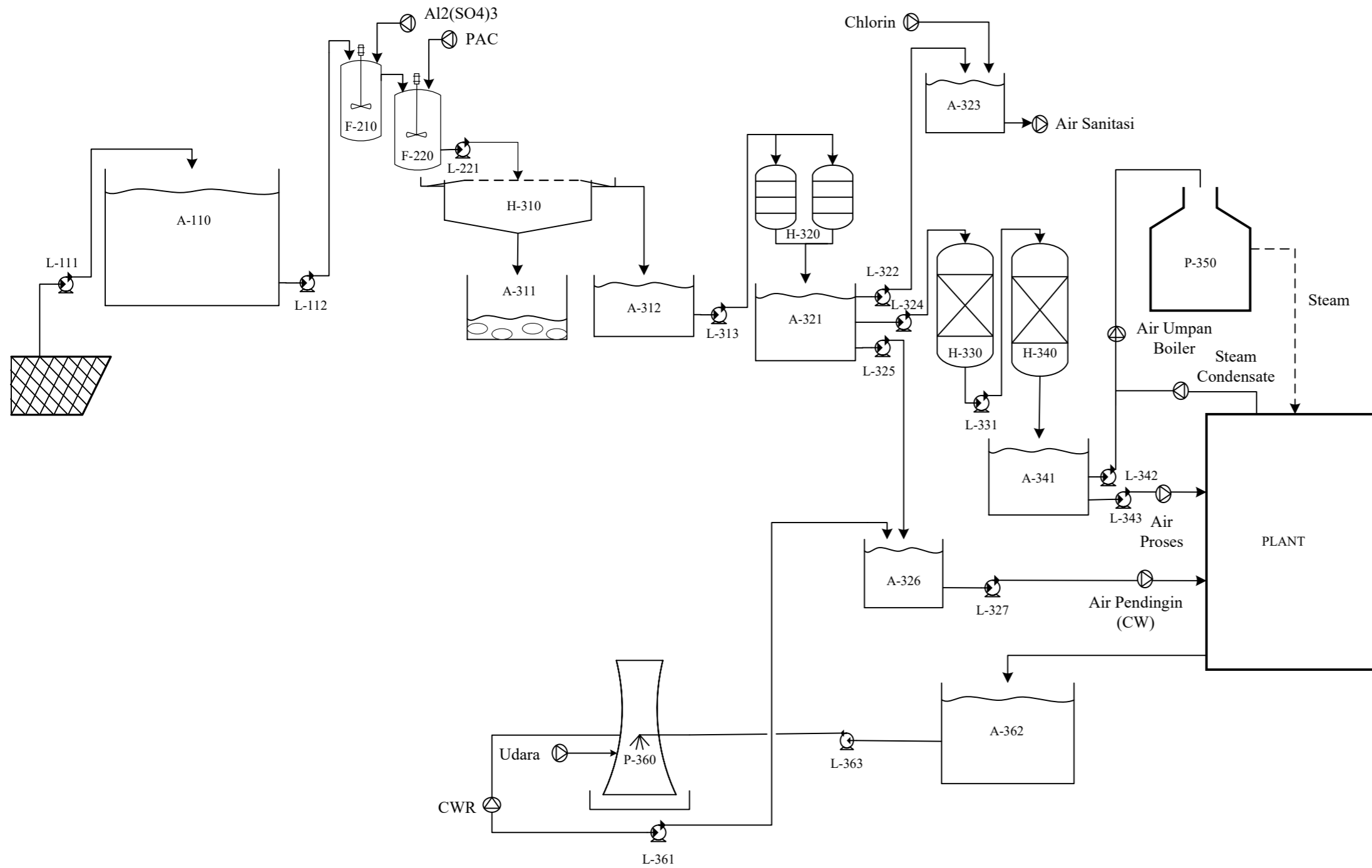

30	L-363	POMPA RECYCLE AIR KE COOLING TOWER
29	A-362	BAK BEKAS AIR PENDINGIN
28	L-361	POMPA COOLING TOWER
27	P-360	COOLING TOWER
26	P-350	BOILER
25	L-343	POMPA AIR PROSES
24	L-342	POMPA AIR UMPAN BOILER
23	A-341	BAK PENAMPUNG AIR LUNAK
22	H-340	ANION EXCHANGER
21	L-331	POMPA ANION EXCHANGER
20	H-330	KATION EXCHANGER
19	L-327	POMPA AIR PENDINGIN KE PLANT
18	A-326	BAK PENAMPUNG AIR PENDINGIN
17	L-325	POMPA BAK PENAMPUNG AIR PENDINGIN
16	L-324	POMPA KATION EXCHANGER
15	A-323	BAK AIR SANITASI
14	L-322	POMPA BAK AIR SANITASI
13	A-321	BAK PENAMPUNG AIR BERSIH-2
12	H-320 B	SAND FILTER-2
11	H-320 A	SAND FILTER-1
10	L-313	POMPA AIR KE SAND FILTER
9	A-312	BAK PENAMPUNG AIR BERSIH-1
8	A-311	BAK PENAMPUNG FLOK (ENDAPAN)
7	H-310	TANGKI CLARIFIER
6	L-221	POMPA TANGKI CLARIFIER
5	F-220	TANGKI FLOKULASI
4	F-210	TANGKI KOAGULASI
3	L-112	POMPA TANGKI KOAGULASI
2	A-110	BAK PENAMPUNG AIR SUNGAI
1	L-111	POMPA BAK PENAMPUNG AIR SUNGAI
NO	KODE	NAMA ALAT
FLOW SHEET UTILITAS PRA RENCANA PABRIK DINATRIUM FOSFAT DARI NATRIUM KARBONAT DAN ASAM FOSFAT DENGAN PROSES KRISTALISASI		
Disusun Oleh	Adila Silmi Nuraini	Mengetahui,
NPM	20031010156	
Dosen Pembimbing I Dosen Pembimbing II	Ir. Mu'tasim Billah, M. T. Lilik Suprianti, S.T, M.Sc	
	PROGRAM STUDI TEKNIK KIMIA FAKULTAS TEKNIK DAN SAINS UNIVERSITAS PEMBANGUNAN NASIONAL "VETERAN" JAWA TIMUR 2024	