

# Estimating the Hydrolysis of Glucose from Bamboo with Micro Controller PID Type Arduino UNO and Fuzzy Method

*by Ni Ketut Sari*

---

**Submission date:** 06-Sep-2022 11:24AM (UTC+0700)

**Submission ID:** 1893451018

**File name:** 6\_Book\_Chapter\_Sari\_2021\_BP\_1827C.pdf (438.16K)

**Word count:** 4759

**Character count:** 26740

---

# Estimating the Hydrolysis of Glucose from Bamboo with Micro Controller PID Type Arduino UNO and Fuzzy Method

Ni Ketut Sari<sup>1\*</sup>, Dira Ernawati<sup>2</sup>, Intan Yuniar Purbasari<sup>3</sup> and Basuki Rahmat<sup>3</sup>

DOI: 10.9734/bpi/naer/v12/1827C

---

## ABSTRACT

Glucose needs each year has increased significantly while glucose production has decreased, this is because supplies of the raw materials limited, where bamboo is one of the raw material alternatives to glucose. The selection of bamboo plants based on levels of cellulose which ranges from 42.4%-53.6%, bamboo plants are plants that can grow quickly and easily grown in various regions in Indonesia. The purpose of research on the hydrolysis process of bamboo using a Proportional Integral Derivative (PID) microcontroller is to digitally process hydrolysis in determining optimal temperature and glucose levels using the Fuzzy method and the Delphi programming simulation language. The production of glucose from bamboo using hydrolysis and pretreatment process, in the hydrolysis process of the microcontroller equipped PID type Arduino UNO, the application of microcontrollers PID using the Fuzzy method and simulation language Delphi programming. Research results in the form of the temperature profile, levels of cellulose hydrolysis time function, and the function time of the hydrolysis of glucose levels. At the time of the detailed set point temperature profile 97°C, at an early stage shows the result of the PID process control with fault temperature below ten°C, the temperature as measured 94,696°C, hydrolysis time 20 seconds. As time went on the hydrolysis process control, PID shows the temperature measured is 96.59°C, at 137 seconds, measured temperature shows 97°C following the temperature set point, used as a basis to design tools in the process of hydrolysis. Optimization of cellulose levels function hydrolysis time is 18.7% and the optimization of the hydrolysis time function of glucose levels is 23,6%. Process design with the production of glucose from bamboo with hydrolysis equipped microcontroller control PID temperature obtained the optimum levels of glucose.

*Keywords: Arduino; fuzzy method; glucose; hydrolysis.*

## 1. INTRODUCTION

Bamboo is one of the materials containing cellulose is quite high and used when the process of hydrolysis of bamboo that does not include lignin and pentose previously done the method of pretreatment and not lignin. The process used is the best process of biological or chemical means to optimize the production of glucose. On the process of hydrolysis produces glucose levels with 23.6% of the weight of the bamboo [1]. The output of glucose from lignocellulose depend on the process of pretreatment, chemical, enzymatic hydrolysis. The proper pretreatment is to use acid, alkaline, hydrogen peroxide, bursts of steam, steam, ammonia fiber expansion [2], Sodium chloride [3], dilute sulfuric acid in removing hemicellulose fraction of substrate lignocellulose [4].

Pretreatment is a significant and critical as one step in a process that is effective in the process of converting biomass into glucose, making it a potential to be developed to be more efficient and

---

<sup>1</sup>Department of Chemical Engineering, Universitas Pembangunan Nasional "Veteran" Jawa Timur, Surabaya, Indonesia.

<sup>2</sup>Department of Industrial Engineering, Universitas Pembangunan Nasional "Veteran" Jawa Timur, Surabaya, Indonesia.

<sup>3</sup>Department of Informatics, Universitas Pembangunan Nasional "Veteran" Jawa Timur, Surabaya, Indonesia.

\*Corresponding author: E-mail: ketutsari.tk@upnjatim.ac.id;

economical. Pretreatment is intended to enhance the capabilities of the surface area (porosity) cellulose so that it can increase the conversion of cellulose into glucose. Pretreatment is required to remove the lignin and hemicellulose, cellulose crystals level decreases, thereby increasing the fraction cellulose, and increases the porosity of the material [5].

Availability of starch (liquid waste rice flour) and cellulose (bulrush and bamboo) are available in substantial quantities in Indonesia. Hydrolysis is a process for the breakdown of cellulose into glucose; it is a raw material which gets less attention after raw material analysis have starch, cellulose and glucose levels, have potential as glucose feedstock. The Bamboos used in the hydrolysis process is those that do not contain lignin and pentose that previously performed pretreatment and not lignin process. This research is to produce glucose as a feedstock for bioethanol, knowing pentose and impurities remaining in bamboo solution. This study has the objective to provide glucose and glucose as well as an industrial prototype as a reference in developing bioethanol industry in Indonesia. It needs to study in the future, what is the best process that we can use, biology process or chemical process using Na-OH, H-Cl, and H<sub>2</sub>SO<sub>4</sub> that can optimize glucose production. The enzyme treatment is also significant because the enzyme has an optimal condition, temperature and the degree of acidity (pH) and when the yeast is in optimal conditions, it can increase its work rate. The comparison obtained can be used as a basis for the design of a prototype glucose production processes and equipment. Resulting from not lignin and hydrolysis process are glucose, liquid waste rice flour on 9.98% glucose contain, bulrush on 37.9% glucose contain, and bamboo on 23.6% glucose include [6].

Bamboo contains cellulose and high glucose, reduce the amount of lignin and pentose pretreatment process and not lignin, filtrate glucose produced in the fermentation using enzymes. From the process of fermentation obtained bioethanol with (18-22)% [7]. The production of glucose in simulations with hydrolysis using the Mat-lab programming language, which in appearance of the graphs the results using the Exell tool, less effective and efficient, so for the visualization needed programming languages object-oriented, in addition to natural developed at, the other has the advantage in a software project can use various programming languages that support object-oriented programming [8].

PID controllers used for motor control applications because of its simple structure and control algorithms are easy to understand. The parameters of the controllers generally use steady-state error, frequency response method or Ziegler-Nichols. This method has a successful outcome but quite a long time and to get a satisfactory system response. Intelligent control-based Artificial Intelligent (AI) has been developed to improve the conventional controls. Design of DC motor control model using some kinds of powers, the PID control tuning with auto-tuning PID mat-lab, which tuning with Ant Colony Optimization (ACO) to control the speed of a DC motor, is expected to have steady state error, settling time and overshoot. Performance results in the model DC motor speed control using Ant Colony Optimization PID (PID-ACO) were found to have faults steady state, continuous and overshoot time better than PID Auto-tuning Mat-lab, the Ziegler Nichols PID (PID-ZN). The result of the PID-ACO programs in this study is the best controller with the fastest time of about 0.55 seconds and overshoot the smallest 1.017 [9].

A suitable control system has resistance to disturbance and responds quick and accurate. An Integral Proportional control system on Derivative (PID) when made very sensitive, then the system response against disturbance produces mostly undershoot/overshoot, so the higher oscillation occurs. In PID control system with fuzzy logic to minimize overshoot and undershoot/recovery time from the system response. Fuzzy logic control system designed with two input IE error and delta errors and output speed of the motor. A significant output of the fuzzy logic control system is only 50% of PID control. From the design of the system is expected in the overall control system which is a hybrid between PID Control with Fuzzy logic can produce a better system response [10].

The chemical procedure in bioethanol cultivation consists of the procedure of pretreatment, delignification, hydrolysis and fermentation, it ready with a micro-controller Arduino with a fuzzy approach the use of Delphi. Research effects within side the shape of pace profiles, residual glucose levels, bioethanol characteristic fermentation time. Fermentation time with fermiol most suitable at 6 days, the very best yield of bioethanol 31.7%, the very best residual glucose awareness 3.9%, filtrate

bamboo 250 ml. Result of jogging the Arduino kind Controller micro application with the bushy approach the use of the Delphi language on the time of 137 seconds with a fixed factor of ninety seven 0C, due to jogging an evaluation application from controllers IE Auto-tuning PID with overshoot 217 (0.08) slurries Time 5.26 and PID ACO with overshoot 202 (0.018) slurries time 0.55 seconds [11].

From extraordinary fruit through-products, durian holds a promising angle that rests on its abundance, notable carbohydrate content material and restricted utilization till now. The first-ever usage of durian seeds for sugar manufacturing optimized situations via alkaline hydrolysis. An easy shape of sugar changed into extracted through various 4 parameters, specifically substrate loading, NaOH attention, hydrolysis time and hydrolysis temperature. Response floor technique primarily based totally at the Box-Behnken layout changed into hired to define the maximum most advantageous parameter values. Analysis of variance discovered that the quadratic as it should be with the order of importance as substrate loading hydrolysis time NaOH attention hydrolysis temperature. The optimized situations for decreasing sugar yield, as excessive as 204 g/L, corresponded to 50 g/L substrate loading, 0.522 M NaOH, 60 second of hydrolysis time and 80°C hydrolysis temperature [12].

Cellulosic ethanol has attracted a good deal interest as it's far of excellent advantage to social and environmental sustainability. We invented a singular pretreatment method, **Densifying Lignocellulosic biomass with alkaline Chemicals (DLC)**, and studied DLC on Corn Stover (DLC-CS) containing calcium hydroxide yielded 21.4 g of ethanol consistent with a hundred g of CS, which changed into similarly superior to 25.3 g of ethanol consistent with a hundred g of CS the usage an ordinary steam autoclave. An ethanol titer as excessive as 70.6 g/L changed into achieved, for the primary time, without washing or cleansing of the pretreated biomass. These promising consequences proven the excellent ability of DLC pretreatment for lignocellulosic biofuel production [13].

Enzymatic pretreatment is rising as a green device for the extraction of biofuel precursors from algal biomass. Algal biomass pretreatment optimization changed into performed the usage of the Taguchi method. Maximum sugar yield from algal biomass changed into discovered at a substrate awareness of 4 g/L, with a 5% enzyme load at temperature 60°C, pH 5.5, and shaking velocity of 8 rpm. In contrast, most COD (1350 mg/g biomass) changed into received at 2 g/L substrate awareness with enzyme load of 20% v/v, at 60°C, pH four, and shaking velocity of 100 rpm. The gift observations set up that procedure situations required for enzymatic pretreatment of algal biomass ought to be decided on in keeping with the favored biofuel type [14].

The production of glucose from bamboo is experimental research furnished the application technology of the fuzzy control the Arduino UNO types in temperature.

## 2. APPLICATION OF PID IN THE PROCESS HYDROLYSIS

Application technology of microcontroller PID temperature type of Arduino UNO for the production of glucose from bamboo by hydrolysis to obtain temperature profiles against hydrolysis time retrieved precise and accurate results. With this application, it will be extracted the right temperature range, during the process of hydrolysis of the already determined the temperature set point, temperature control with easy tools in the design process of hydrolysis.

### 2.1 Proportional Integral Derivative (PID)

PID controllers used for motor control applications because of its simple structure and control algorithms are easy to understand. The parameters of the controllers generally use Try and Error frequency response method or Ziegler-Nichols. This method has a successful outcome but quite a long time and to get a satisfactory system response. Intelligent control-based Artificial Intelligent (AI) has been developed to improve the conventional controls. Design of DC motor control model using some kinds of powers, i.e., the PID control tuning with mat-lab, the PID auto-tuning with Ant Colony Optimization (ACO) to control the speed of a DC motor, is expected to have steady state error, settling time and overshoot. DC motor output routed to invert input PID which further calculate substantial difference or mistake that is later used to improve PID constants.

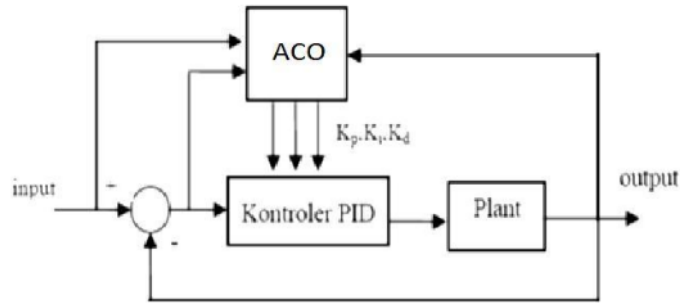

**Fig. 1. Controller PID-ACO for plant**

PID control is a composite control system between the proportional control, integral, and derivative, the application of this method in a closed system, where the reference input function is a ladder (step). Controllers used Proportional Controllers (PC), raised from 0 to a critical value of proportional controllers, so gained output that continually oscillates with the same amplitude, critical appraisals of proportional controllers called ultimate gain. The amount of the final period, obtained after the production of the system achieve continuous oscillation conditions.

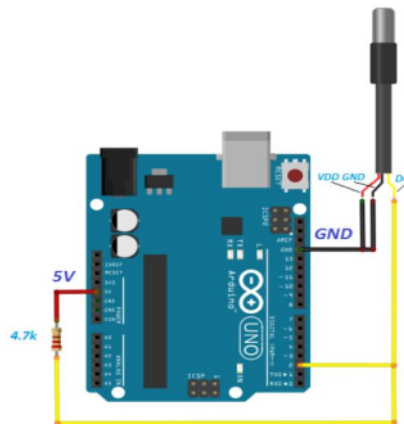

**Fig. 2. Configuration hardware of temperature sensor DS18B20**

Common characteristics used in the control of such a system include the stability, accuracy, speed of response and sensitivity [15]. Proportional control in action, the output of the control system necessarily proportional to its input. The output signal is the strengthening of a signal fault with specific factors, and it is strengthening proportional factor and constant of the system, which expressed with a factor proportional, where factor proportional has a high response/quick. Integral control in action, the output of the controller is continually changing throughout the deviation, and the speed of change of the production is proportional to error, its constant declared ( $K_i$ ), where it has a high sensitivity, by way of the reduction of error resulting from the feedback signal. The high the value of  $K_i$  so sensitivity will be higher, but the time required to achieve stability faster, and vice versa. While the action control of the derivative works based on the rate of change of the junction, so the type of the controller is always used together with proportional and integral controller, its constant declared ( $K_d$ ), where it affects the stability of the system, due to the action of this control can reduce errors.

$$D = K_p e(t) + K_i \int e(t)dt + K_d \frac{de(t)}{dt} \tag{1}$$

$$P_{Term} = K_p e(t) \tag{2}$$

$$I_{Term} = K_t \int e(t)dt \tag{3}$$

$$D_{Term} = K_d \frac{de(t)}{dt} \tag{4}$$

The sensor is a digital sensor DS18B20 has 12-bit internal ADC, high precision with reference voltage of 5 volts, the smallest change in temperature equates 0.0012 volts, in the temperature range -10 to +85 degrees Celsius, sensor DS18B20 has the sensor accuracy is +/-0.5 degrees, the sensor works using the 1-wire communication protocol (one-wire).

### 2.2 Experiment Process of Hydrolysis

The production of glucose from bamboo is experimental research furnished the application technology of microcontroller Proportional Integral Derivative (PID) control the Arduino UNO types in temperature, with the study as follows:

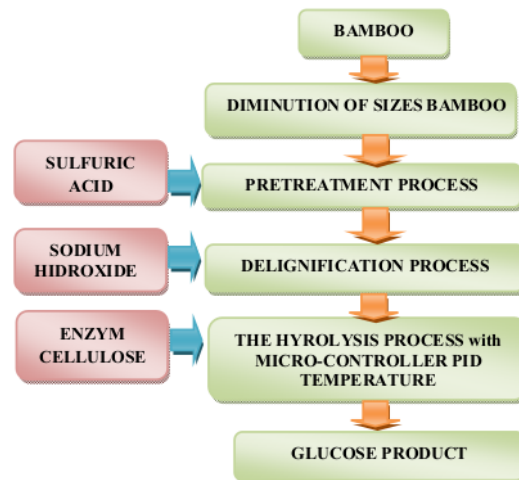

**Fig. 3. Block diagram of glucose production from bamboo fitted microcontroller PID**

### 3. RESULTS AND DISCUSSION

#### 3.1 Results of Cellulose and Glucose Hydrolysis Process

The pieces and refined fiber of bamboo with an approximate length of 5 cm and polished thread 200 mesh were to obtain the high levels of glucose and cellulose before bacillus, and H-Cl solution hydrolyzed it. It should in powder form so that cellulose hydrolyzed perfectly. However, that process took a higher cost. Besides, bulrush in the powder form could suffer the physical destruction, thus causing the damage of the glucose group. The drying process of bulrush was naturally done first in the room temperature. The drying process was done in an oven at 100°C for 3 hours.

It was for cost savings, and the dryer process aimed to reduce the water content in ethanol. The water level that was permitted by Standart National Indonesia (SNI) was 1%. The decreasing of pH from

pretreatment material was affected by the addition of H-Cl volume 7%v/v because the requiring pH for fermentation process was 4,5. Before doing the hydrolysis process, the pH of the filtrate measured according to the terms of the fermentation process that is approximately 4.5, to obtain pH 4.5, the addition of Na-OH done if pH of the filtrate was under 4.5 and the addition of citric acid if the filtrate pH was above 4.5.

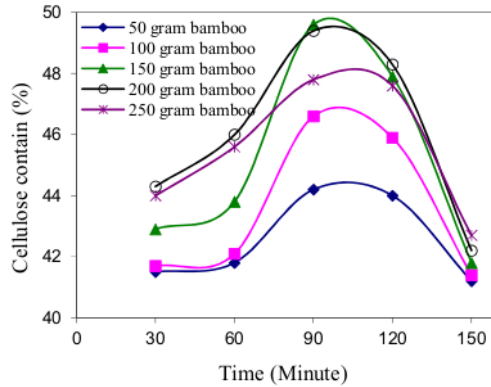

Fig. 4. Contains cellulose function hydrolysis time

In Fig. 4 at the time of 90 minutes, 47.8% cellulose concentration trend at the maximum weight of 150 grams of bamboo. On the research [12], selulose 47.8% concentration obtained from hard and soft wood. One of the materials that contain cellulose that is bamboo. The percentage of cellulose on bamboo i.e., 42.4%-53.6%. The percentage of other components contained of bamboo lignin is (19.8%-26.6%), pentosan (1.24%-3.77%), extractive substances (4.5%-9.9%), water (15%-20%), substance followup (1.24%-3.77%), and SiO<sub>2</sub> (1.78%-0.1%). The percentage of cellulose makes the larger bamboos as one source of bioethanol cellulose [3]

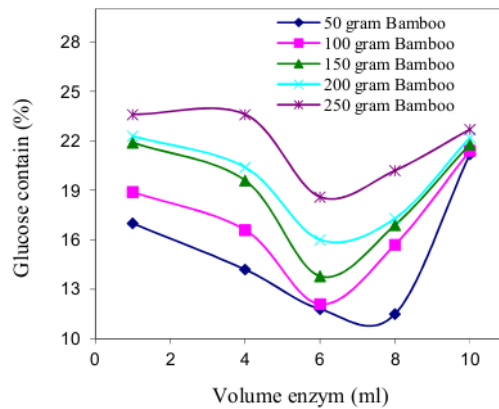

Fig. 5. Contains glucose function volume enzyme

In Fig. 5 on a volume of 4 ml enzyme, glucose concentration maximum 23.6% on trend on large bamboo 250 grams, maximum levels obtained from the cellulose of wood 18.7%. With the results obtained allows the bamboo can be as the raw material alternative to bioethanol. Several factors that encourage research utilization intensive do lignocellulose materials into a source of energy, in this case, ethanol [16]. First, the needs and energy consumption continued to increase from year to year,

while natural resources which can generate energy depleted because most of the current sources of energy derived from natural resources that are not renewable, such as oil, gas, and coal. Second, bioethanol has better characteristics compared to gasoline because it can increase the efficiency of combustion [17].

### 3.2 Proportional Integral Derivative (PID)

OMRON's Industrial Temperature Regulator developed hybrid control system of PID-fuzzy logic. Then applied on micro-technology a Proportional Integral Derivative temperature type Arduino on hydrolysis process using the Fuzzy method. The primary system is the control of PID, whereas fuzzy logic here serves to improve response and recovery time against disturbance as shown in Fig. 6. The output of the fuzzy control unit produced has a smaller load of the control of PID, meaning that range from the output membership function has the set.

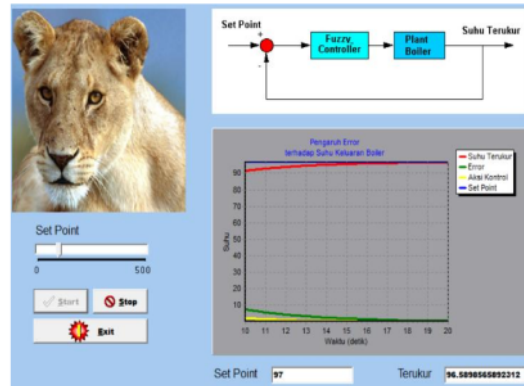

**Fig. 6. Temperature profile function of time on the set point (97 °C) and the measured temperature is 94.696 °C.**

At the time of 14 seconds, set point 97°C, the action control and error show the temperature below ten °C and the temperature of the measured 94.696°C. With the passage of time will be retrieved according to temperature set point, such as a Fig. 6. At the time of 20 seconds, the set point 97°C shows the action control, and error shows the temperature under 0°C and the measured temperature is 96.59°C, with the passage of time will be retrieved according to the temperature set point.

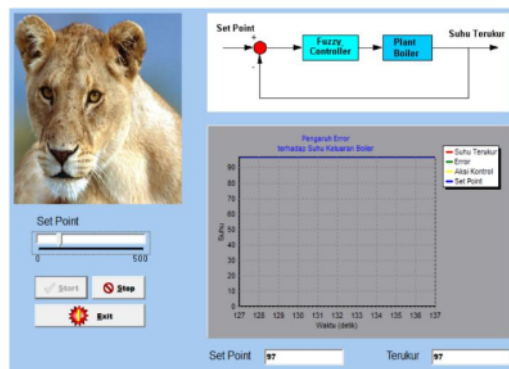

**Fig. 7. Temperature profile function of time on the set point (97 °C) and the measured temperature is 97 °C.**



At the time of 137 seconds, set point 97°C shows the action control and error shows the temperature under 0°C and the measured temperature is 97°C as Fig. 7. Micro- technology an Integral Proportional temperature Derivative controller type Arduino UNO using the Fuzzy method can use as a reference in the design of the excellent hydrolysis process tools.

#### **4. CONCLUSION**

The hybrid control system capable of generating a response and recovery time is better and resistant to disturbance, is evident from the results of testing the system with the awarding of the disorder, an occurrence of undershoot and overshoot of the granting of discharge loads and load can be mute. To get a good response on hybrid PID control system –Fuzzy method can be done tuning evaluation rules as well as the membership function value to widen the way crisp input, with the aim to dampen overshoot.

At the time of 137 seconds, set point 97 °C shows the action control and error shows the temperature under 0 °C and the measured temperature is 97 °C. Micro-technology an Integral Proportional temperature Derivative controller type Arduino UNO using the Fuzzy Method, can be used as a reference in the design of the excellent hydrolysis process tools at optimization of the cellulose levels function hydrolysis time is 18.7%, and the optimization of the glucose levels function hydrolysis time is 23.6%.

#### **ACKNOWLEDGEMENT**

The authors would like to acknowledge the financial support of the Directorate Research and Public Service. The Directorate of Research and Development Strengthening. The Ministry of Research, Technology, and Higher Education of the Republic of Indonesia with the Research-Based Competence Grant. Contract Number: 083/SP2H/LT/DRPM/2018.

#### **COMPETING INTERESTS**

Authors have declared that no competing interests exist.

#### **REFERENCES**

1. Sari NK, Nico Y, Tika L, Dira E. Hydrolysis of cellulose from bamboo with biology process using enzyme. *Journal Advanced Science Letters*. 2017;23(12):12235-12238.
2. Teymouri F, Peres LL, Alizadeh, Dale BE. Optimization of the ammonia fiber explosion (AFEX) treatment parameters for enzymatic hydrolysis of corn stover. *Bio-resource Tech*. 2005;96: 2014-2018.
3. Kumar A, Singh LK, Ghose S. Bioconversion of lignocellulose fraction of water-hyacinth (*Eichhornia*) hemicellulose acid crassipes hydrolysate to ethanol by *pichia stipilis*. *Bio-resource Technology*. 2009;100:3293-3297.
4. Sari NK, Sutiyono S, Luluk E, Dira E, Putu W, Tatik SH. Bioethanol production from liquid waste of rice flour with batch process. *Proceeding MATEC Web of Conference*. 2016; 58(01003):1-5.
5. Lee JS, Parameswaran B, Lee JP, Park SC. Recent development of crucial technologies on cellulosic ethanol production. *Journal of Scientific and Industrial Research*. 2008;67(11):965-873.
6. Sari NK, Pudjiastuti, Ketut Sumada. Comparison production glucose from starch and cellulose using delignification hydrolysis process. 2017;23(12):12318-12321.
7. Sari NK, Dira E. Comparison production bioethanol from cellulose using batch distillation and flash distillation process, *Journal of Geomate*. 2018;15(50):76-81.
8. Sari NK, Pujiastuti C, Nyoman Abdi I. Bioethanol production comparison of elephant grass and liquid waste plant wheat boga sari. *Internasional Seminar on Chemical Engineering Bio-Energy, Chemicals and Materials (BioEnChe 2013)*, ITB Bandung, Indonesia, ISSN 2354-5917, 2013, Module: BE.02; 2013.

9. Mochammad Nur Masrukhan, Mochamad Piono Mulyo, Dwi Ajiatmo, Machrus Ali, Optimization of speed motor DC using PID with tuning *ant colony optimization* (ACO) Controller, Proceeding SENTIA ISSN: 2085-2347, Politeknik Negeri Malang. 2016;8:B-49–B-52.  
Mochammad Nur Masrukhan, Mochamad Piono Mulyo, Dwi Ajiatmo dan Machrus Ali, Optimasi Kecepatan Motor Dc Menggunakan Pid Dengan Tuning *Ant Colony Optimization* (Aco) Controller, Prosiding SENTIA ISSN: 2085-2347, Politeknik Negeri Malang. 2016;8:hal. B-49 – B-52.
10. Samsul Bachri M. Hybrid control system of PID-Fuzzy logic on DC motor speed settings. *Makara Technology*. 2004;8(1):25-34.  
Samsul Bachri M. Sistem Kendali Hybrid Pid - Logika Fuzzy Pada Pengaturan Kecepatan Motor DC, *Makara, Teknologi*. 2004;8(1):hal. 25-34.
11. Sari NK, Purbasari IY, Rahmat B. Bioethanol and residual glucose from filtrate bamboo with micro controller of speed at fermentation process. 5th International Conference on Food, Agriculture and Natural Resources (FANRes 2019), Publisher Atlantis Press Publish. 2020; 428-432.
12. Chriswardana TH, Mulyaningsih Y, Mulyaningsih Y, Bahar AH, Riayatsyah TBI. Optimization of sugar production from Durian seeds via alkaline hydrolysis for second-generation bioethanol production. *Clean Energy*. 2021;375-386.
13. Xiangxue Chen, Xinchuan Yuan, Sitong Chen, Jianming Yu, Rui Zhai, Zhaoxian Xu and Mingjie Jin, "Densifying Lignocellulosic biomass with alkaline Chemicals (DLC) pretreatment unlocks highly fermentable sugars for bioethanol production from corn stover", *Journal Green Chemistry Advance Article*. 2021;13.
14. Shashi Bhushan, Mohit Singh Rana, Mamta Bhandari, Ashwini Kumar Sharma, Halis Simsek and Sanjeev Kumar Prajapati. Enzymatic pretreatment of algal biomass has different optimal conditions for biogas and bioethanol routes. *Chemosphere*. 2021;284:131264.
15. Jacob JM. *Industrial control electronics application and design*. Prentice Hall Inc. Englewood Cliffs, New Jersey; 1988.
16. Nibedita Sarkar, K.G. Sumanta, Satarupa Bannerjee, Kaustav Aikat. Bioethanol production from agricultural wastes: An overview. *Renewable Energy*. 2012;37:19-27.
17. Limayem A, Ricke SC. Lignocellulosic biomass for bioethanol production: current perspectives, potential issues, and future prospects. *Progress Energy Combust. Sci*. 2012;38:449-67.

**Biography of author(s)**



**Intan Yuniar Purbasari**

Department of Informatics, Universitas Pembangunan Nasional "Veteran" Jawa Timur, Surabaya, Indonesia.

**Research and Academic Experience:**

1. Completed Bachelor of Computer (Institut Teknologi Sepuluh Nopember, Surabaya) and Master of Science (The University of Queensland, Australia)
2. Lecturer in Department of Informatics, Faculty of Computer Science since 2004
3. Decision Support System for Lecturers' Credit Assessment (Research grant 2016)
4. Mobile-based Spatial Map Application of Horticulture Produce (Research grant 2018)
5. A Deep Learning-based Intelligent Drone for Plant Disease Detection (Research grant 2019)
6. Analysis of Determining Abnormal Inmate's Behaviour in Prison as Prevention of Violence Based on Avatar Movement using Motion History Image and Deep Learning Methods (Research grant 2020)
7. A Deep Learning-based Intelligent Bela Negara Robot for Object Detection (Research grant 2021)

**Research Area:** Intelligent System and Robotics, Machine Learning, Data Knowledge Engineering

**Number of Published papers:** 45



**Basuki Rahmat**

Department of Informatics, Universitas Pembangunan Nasional "Veteran" Jawa Timur, Surabaya, Indonesia.

**Research and Academic Experience:**

1. Completed Bachelor of Instrumentation Physics (Institut Teknologi Sepuluh Nopember, Surabaya), Master of Instrumentation and Control (Institut Teknologi Bandung, Indonesia), and Doctor of Electrical Engineering (Institut Teknologi Sepuluh Nopember, Surabaya).
2. Lecturer in Department of Informatics, Faculty of Computer Science since 2006
3. Rice Rat Attack Control Method (*Rattus argentiventer* Rob & Kloss) Based on Ultrasonic Technology to Increase 50% Effectiveness and 15% Cost Efficiency (Research KKP3T Litbang Deptan.go.id) (Research grant 2010).
4. Remote Soil Quality Monitoring Using IDAS (Internet-Based Data Acquisition System) and SMS Gateway (KKP3T Research Research and Development Deptan.go.id) (Research grant 2011).
5. Making Remote Soil Quality Control Equipment with IDACS (Internet-Based Data Acquisition and Control System) Technology and SMS Gateway (2nd Year Research KKP3T Litbang Deptan.go.id) (Research grant 2012).
6. Making Intelligent Fishcarelab System (IFS) As Internet-Based Remote Fish Cultivation System (University Excellence Research) As Research Member (Research grant 2015).
7. Making Intelligent Fishcarelab System (IFS) As Internet-Based Remote Fish Cultivation System (University Excellence Research) As Research Member. (2nd Year Research) (Research grant 2016).
8. Tracking and Recognition System for Indonesian Vehicle Number Plates Based on Intelligent Systems (Doctoral Dissertation Research) (Research grant 2016).
9. Fuzzy Programming and Artificial Neural Networks for Intelligent Control Systems (Learning Quality Improvement Research) (Research grant 2018).
10. Smart Robot Programming with Arduino (Learning Quality Improvement Research) (Research grant 2019).
11. Deep Learning Programming with Python (Learning Quality Improvement Research) (Research grant 2020).
12. Creation of Cloud Internet of Things (IoT) as a Internet Based Control System Application (Research grant 2021).

**Research Area:** Intelligent System, Drones, and Robotics, Machine Learning, Intelligent Control System.

**Number of Published papers:** 21

---

© Copyright (2021): Author(s). The licensee is the publisher (B P International).

**DISCLAIMER**

This chapter is an extended version of the article published by the same author(s) in the following journal.  
Atlantis Highlights in Engineering (AHE), 1: 35-39, 2018.

# Estimating the Hydrolysis of Glucose from Bamboo with Micro Controller PID Type Arduino UNO and Fuzzy Method

---

## ORIGINALITY REPORT

---

11%

SIMILARITY INDEX

8%

INTERNET SOURCES

5%

PUBLICATIONS

2%

STUDENT PAPERS

---

## MATCH ALL SOURCES (ONLY SELECTED SOURCE PRINTED)

---

1%

★ Xiangxue Chen, Xinchuan Yuan, Sitong Chen, Jianming Yu, Rui Zhai, Zhaoxian Xu, Mingjie Jin. "Densifying Lignocellulosic biomass with alkaline Chemicals (DLC) pretreatment unlocks highly fermentable sugars for bioethanol production from corn stover", Green Chemistry, 2021

Publication

---

Exclude quotes Off

Exclude matches < 10 words

Exclude bibliography On